

Secoroc COP 20

Down-the-hole hammer

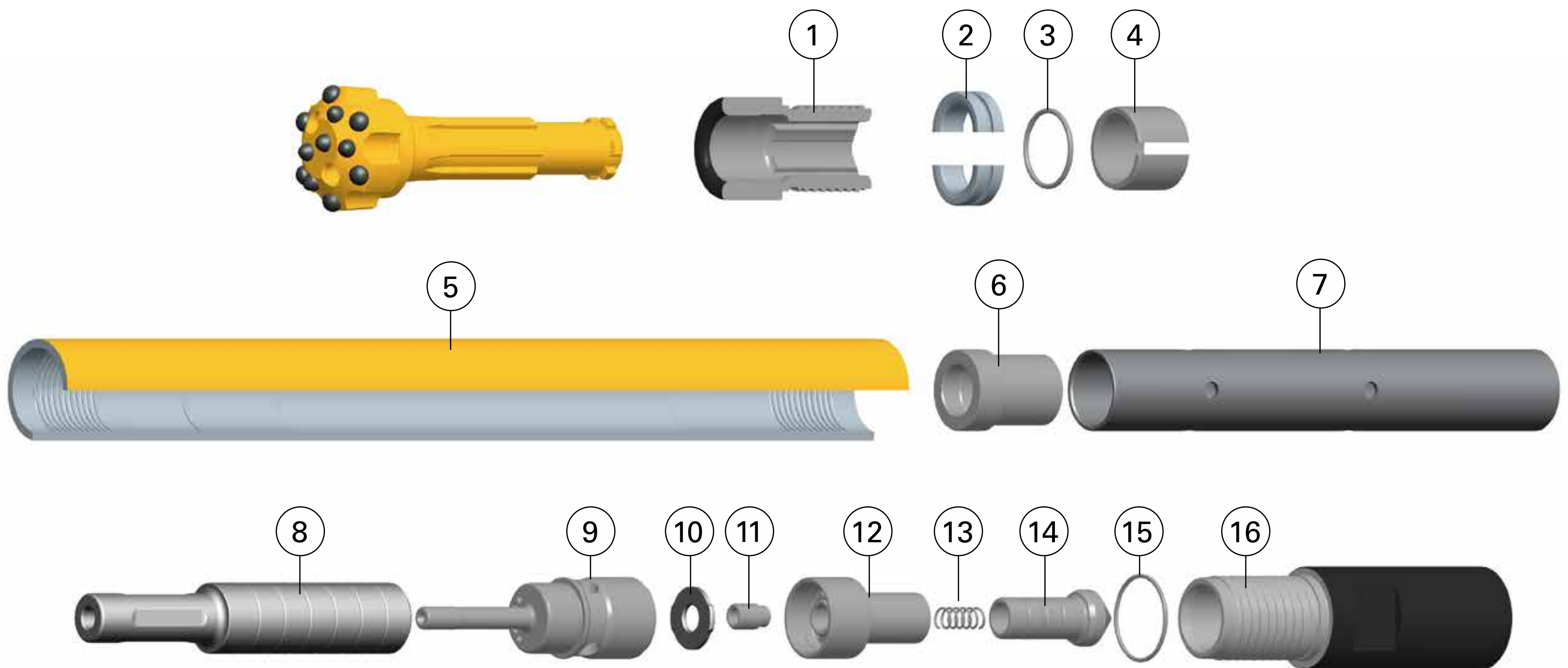

Ref.	Part	Prod. No.	Product code
1	Chuck	93501360	9702-CO-00-40B-44-000-001
2	Bit retaining ring	93501358	9702-CO-00-000-44-000-A02
3	O-Ring* (bit retaining ring)	-	-
4	Split spacer	93501357	9702-CO-00-000-44-000-072
5	Casing	93501356	9702-CO-00-000-00-000-004
6	Bit bearing	93501355	9702-CO-00-000-44-000-056
7	Inner cylinder	93501354	9702-CO-00-000-00-000-048
8	Piston	93501353	9702-CO-00-000-44-000-005
9	Bevelled valve housing	93501352	9702-CO-00-000-00-000-042
10	Disc valve	93501351	9702-CO-00-000-00-000-044
11	Valve centraliser	93501350	9702-CO-00-000-00-000-043
12	Valve chest	93501349	9702-CO-00-000-00-000-015
13	Check valve spring	93501348	9702-CO-00-000-00-000-016
14	Check valve	93501347	9702-CO-00-000-00-000-017
15	O-ring* (backhead)	-	-
16	Backhead, RD 50-6 box	93501752	9702-CO-00-40B-00-000-A20

* Not supplied separately, see kit.

Hammers and kits	Prod. No.	Product code
COP 20 complete, RD 50-6 box.	93501344	9702-CO-00-40B-44-000
Service kit incl. item 3, 13, 14, 15	93501803	9702-CO-00-000-44-000-K70

Wear limits		
Casing	Min OD	56 mm
Piston / Cylinder clearance	Max.	0.23 mm
Piston / Bearing clearance	Max.	0.23 mm
Piston / Valve housing stem clearance	Max.	0.3 mm

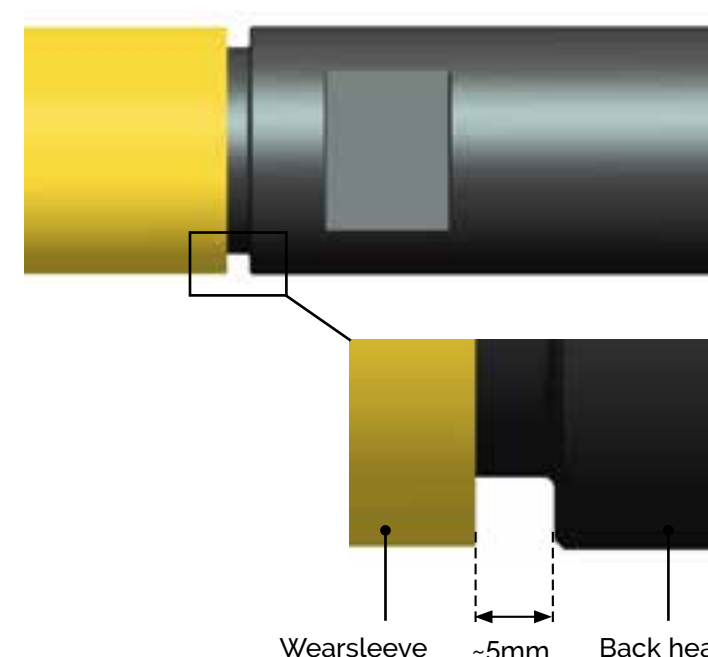

- During assembling the hammer ensure the specified gap between the shoulders of wearsleeve and backhead.
- No gap at the Driver chuck end.